

Drehwinkelverstellung: $\pm 5^\circ$
 Steuerwelle

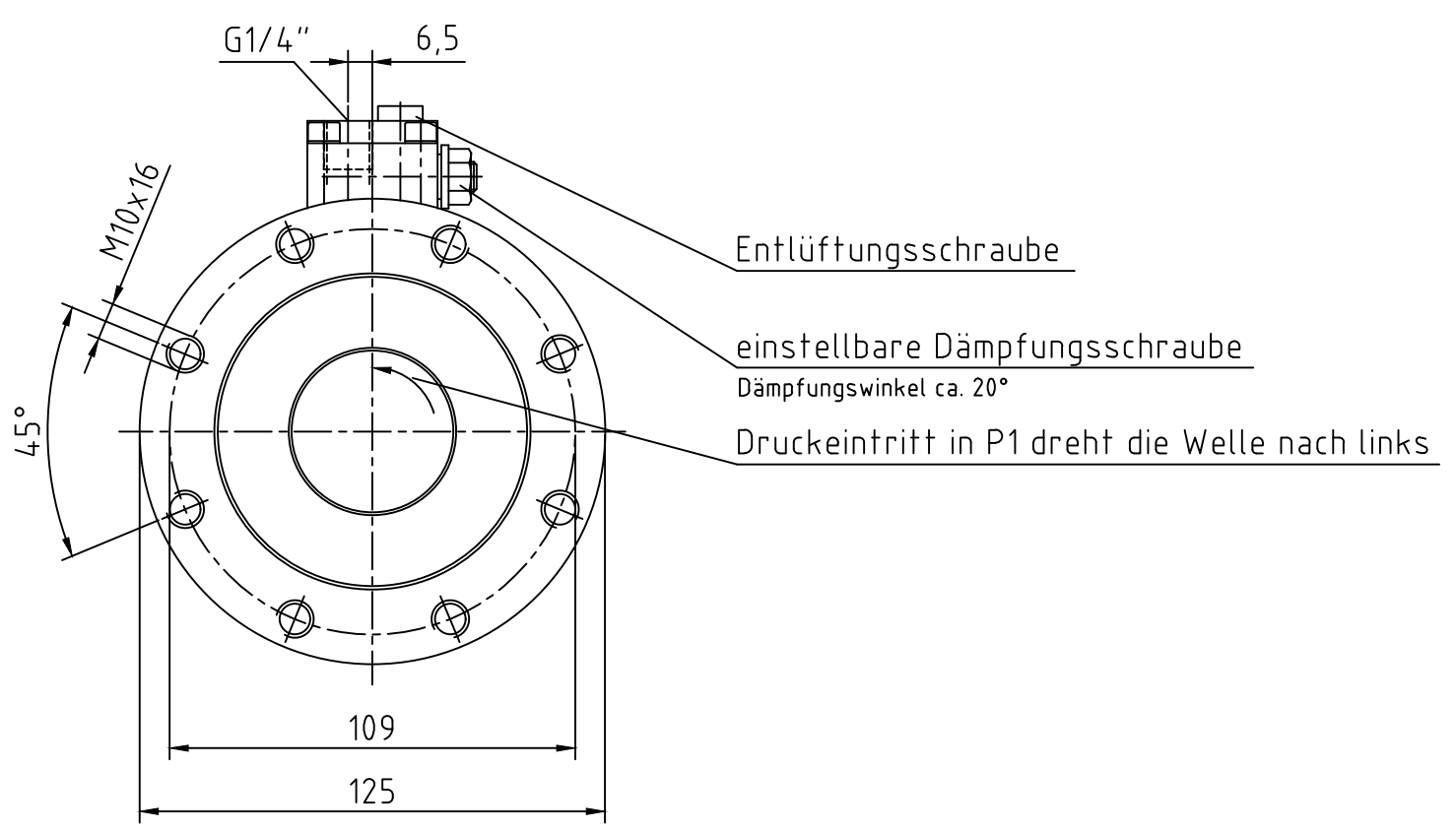

Technische Daten:
 max. Betriebsdruck: 250 bar
 max. Nenndrehmoment: 1427 Nm
 Schluckvolumen für 360°: 0,493 dm³
 Schluckvolumen für 270°: 0,369 dm³

 ROTAT DREH-ANTRIEBE GmbH Hans-Streif-Strasse 1 D-63628 Bad Soden-Salmünster	Dreh-Antrieb RH 80 360° RH 80 270°
---	--